

# DATA SHEET SAND DIGGER TOLLO

Text for invitation to tender | Item No: 511100402



## MATERIALS | SCOPE OF SUPPLY

Sand digger, pre-mounted completely

Tubular frame:	stainless steel, V2A
Saddle seat:	EPDM caoutchouc with steel inlay, 1 piece
Handles:	stainless steel, V2A with balls made of EPDM caoutchouc, 2 pieces
Digger levers:	stainless steel, V2A, 2 pieces
Shovel:	stainless steel, V2A, 1 piece
Foundation anchor:	galvanized steel

## TECHNICAL INFORMATION

Dimensions:

Main dimension:	1380 x 250 mm
Height:	730 mm
Weight:	32 kg
Capacity:	acc. to normative requirements
Dimension largest piece:	1380 x 250 x 1180 mm
Heaviest piece:	26 kg

Max. fall height:	350 mm
Minimum space:	Ø 3000 mm
Required sand:	min. 3,18 m <sup>3</sup>
Recommended surface material:	sand

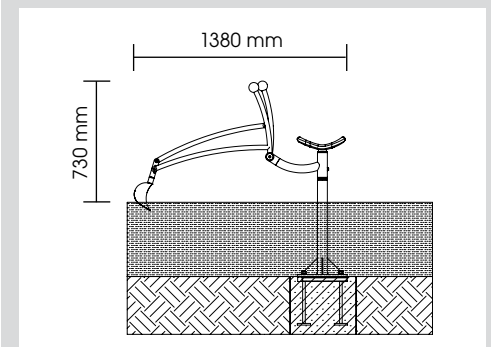
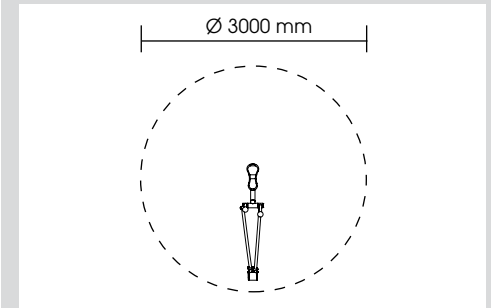

## INSTALLATION

Foundations: 1  
Installation according to our detailed mounting instructions, see [www.stilum.com](http://www.stilum.com)

