

# DATA SHEET SWING PATIS 1

Text for invitation to tender | Item No: 51 2012 402

## MATERIALS | SCOPE OF SUPPLY

Swing, mounted on-location, fixation of the chains and swing bar necessary

Post:	stainless steel, V2A, 2 pieces
Swing bar:	stainless steel, V2A, 1 piece
Swing seat:	EPDM caoutchouc with steel inlay, 1 piece
Chains:	stainless steel 1,80 m, 2 pieces
Tube end caps:	plastic, 2 pieces
Foundation plates:	steel, coated

## TECHNICAL INFORMATION

Dimensions:

Main dimension:	2000 x 200 mm
Height:	2500 mm
Weight:	143 kg
Capacity:	acc. to normative requirements
Dimension largest piece:	480 x 480 x 2840 mm
Heaviest piece:	58 kg

Max. fall height:	1400 mm
Impact protection	
Impact area:	13,65 m <sup>2</sup>
Required safety slabs:	14,00 m <sup>2</sup>
Required lawn grating:	14,00 m <sup>2</sup>
Recommended surface material:	sand, wood chip, gravel, synth. impact protection

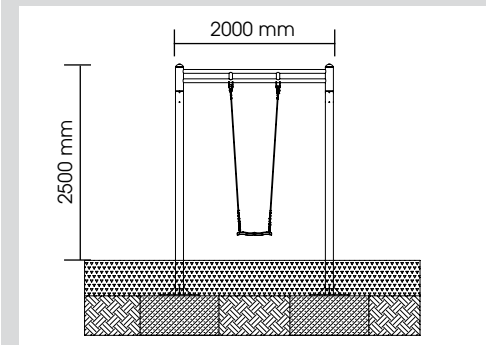
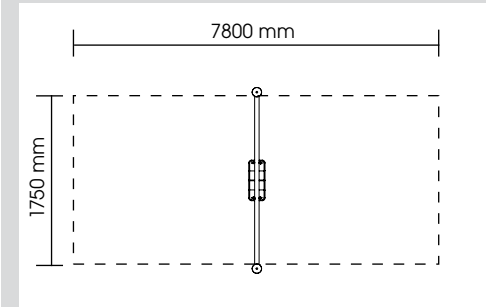

## INSTALLATION

Foundations: 2

Modified installation depth possible  
(special edition)

Installation according to our detailed mounting  
instructions, see [www.stilum.com](http://www.stilum.com)

