

# DATA SHEET SEESAW SHIP NAVIS

Text for invitation to tender | Item No: 51 2517 401



## MATERIALS | SCOPE OF SUPPLY

Seesaw, pre-mounted completely

Seesaw bar:	stainless steel, V2A, coated with slip-resistant EPDM granules 1 piece
Handle bars, axle tubes:	stainless steel, V2A
Rack:	stainless steel, V2A with shaft made of stainless steel and sockets made of plastic
Tube end caps:	balls made of EPDM granules, 2 pieces
Seesaw softener:	EPDM caoutchouc, 2 pieces
Foundation plates:	steel, coated

## TECHNICAL INFORMATION

Dimensions:

Main dimension:	2030 x 1360mm
Height:	1520 mm
Weight:	170 kg
Capacity:	acc. to normative requirements
Dimension largest piece:	2030 x 1360 x 1960 mm
Heaviest piece:	170 kg
Max. fall height:	800 mm
Impact area:	23,54 m <sup>2</sup>
Required safety slabs:	24,75 m <sup>2</sup>
Required lawn grating:	30,00 m <sup>2</sup>
Recommended surface material:	grass, sand, wood chip, gravel, synth. impact protection

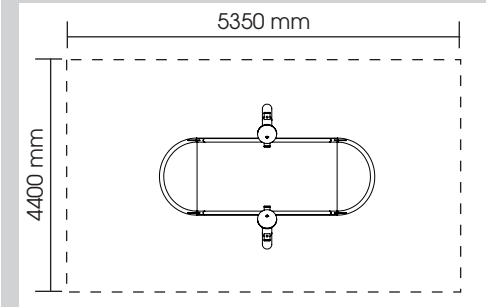

## INSTALLATION

Foundations: 1

Installation according to our detailed mounting instructions, see [www.stilum.com](http://www.stilum.com)

