

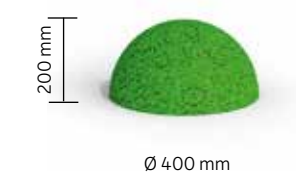

Terrasoft® EPDM Half globe

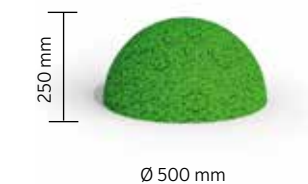

The Terrasoft half globes made of colourful EPDM rubber granules bring joy to any design area. Whether in private gardens as a design feature or in outdoor areas of hotels - with the half globes, outdoor areas can be given a creative edge. The large-volume elements can be used as seating or, when positioned in groups, as a balancing course, all at the same time. The extensive colour choice offers absolutely diverse design possibilities.

ADVANTAGES

- low maintenance, robust
- extraordinary design feature
- Play element

APPLICATION

Half globes with ground anchors can be concreted into a prepared foundation with the help of the ground anchors and thus are permanently fixed.



with Floor anchor
Item no. 2565000109

- Terrasoft® Half globe (L x W x H) Ø 750 x 375 mm | EPDM Gummigranulat | Item no.: 353375yy2
- Terrasoft® Half globe (L x W x H) Ø 500 x 250 mm | EPDM Gummigranulat | Item no.: 353350yy2
- Terrasoft® Half globe (L x W x H) Ø 400 x 200 mm | EPDM Gummigranulat | Item no.: 353340yy2
- Terrasoft® Half globe (L x W x H) Ø 300 x 150 mm | EPDM Gummigranulat | Item no.: 353330yy2

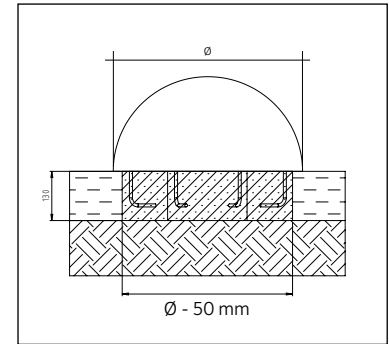

Side view with dimension details „globe“ half globe. The foundation has to be 5 cm smaller than the diameter of the half globe

INSTALLATION INSTRUCTIONS

Half globe with Floor anchor:

The half globes can be embedded with the ground anchors into the prepared concrete foundations to fix them permanently. Take care that the ball is fully supported on a firm surface.

INSTALLATION INSTRUCTIONS

Select the location. Carry out excavation work for the foundation. The foundation has to be 5 cm smaller than the diameter of the half globe.

Set up the concrete foundation acc. to the dimensions indicated with central, horizontal reinforcement (BST 500 S) in the quality class C 20/25. Put the half globe into the foundation. The half globe has to lay on the play level.

Do not allow children to use the equipment during the setting period of 8 – 10 days (depending on weather conditions and foundation size).



Terrasoft Half globe Ø 500 mm
signalyellow



Terrasoft Half globe Ø 300 mm
signalyellow

Colours

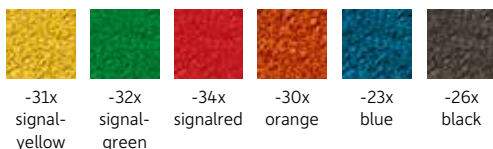

Specifications

