

DATA SHEET BOUNCER XLARGE

Text for invitation to tender | Item No: 51 4828 xx1



MATERIALS | SCOPE OF SUPPLY

Bouncing element fully assembled for installation

Basic frame:	steel hot dip galvanized
Jumping surface:	plastic slats
Cover:	safety slabs
Equipment:	lifting hook, 4 pieces

SAFETY AND USER NOTES

- No somersaults, belly and back jumps
- No food / beverage
- No alcohol / drugs
- No jewellery
- Wear shoes with flat sole
- Use only spare parts from the manufacturer

INSTALLATION

Pit with drainage layer

Installation according to our detailed mounting instructions, see www.stilum.com

TECHNICAL INFORMATION

Dimensions:

Main dimension:	2860 x 1900 mm
Jumping surface:	2380 x 1420 mm
Weight:	350 kg (incl. pallet)
Test load:	1320 kg
Dimensions largest piece:	2860 x 1900 x 433 mm

Max. fall height:	1000 mm
Free space:	6380 x 5420 x 3500 mm
Impact area:	40,47 m ²
Required safety slabs:	38,25 m ²
Required lawn grating:	40,00 m ²
Surface material:	acc. to EN 1176-1

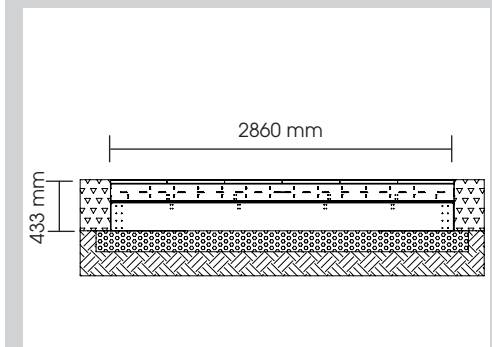
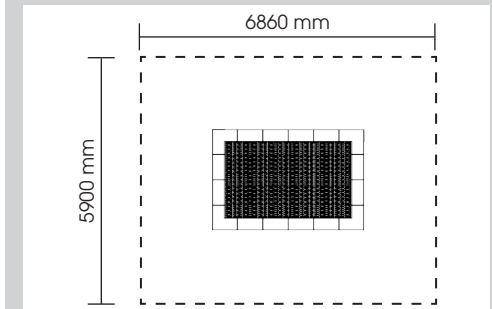
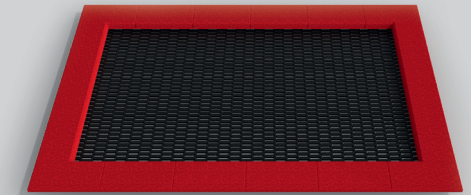

Colour key
(according to part 7 and 8 of item number)

